

EXECUTIVE DESIGN SPECIFICATIONS - SYSTEM WITH STANDARD SIDE TRACK (V2A) SOMFY LT50 (Exploded View)

FOR ILLUSTRATION PURPOSES - NOT DRAWN TO SCALE

Parts Spec

- A Housing Assembly (Top and Back)
(5-1/2" W x 5-1/2" H or 7-1/8" W x 7-1/8" H)
- B Housing Cover (Angled Style)
- C End Cap (L & R) c/w Fasteners
- D Motor Bracket (with Retainer, Stainless Steel, to C)
- E Idler Bearing (Retainer Ringed, Stainless Steel, to C)
- F Electric Motor
- G Roller Assembly (4" / 5") c/w Inserts (L & R)
- H Spring Idler
- I Idler Assembly Retainer Clips
- J Drive Gear (Motor Crown)
- K Mounting Angle (1 x 2" or 2 x 2")

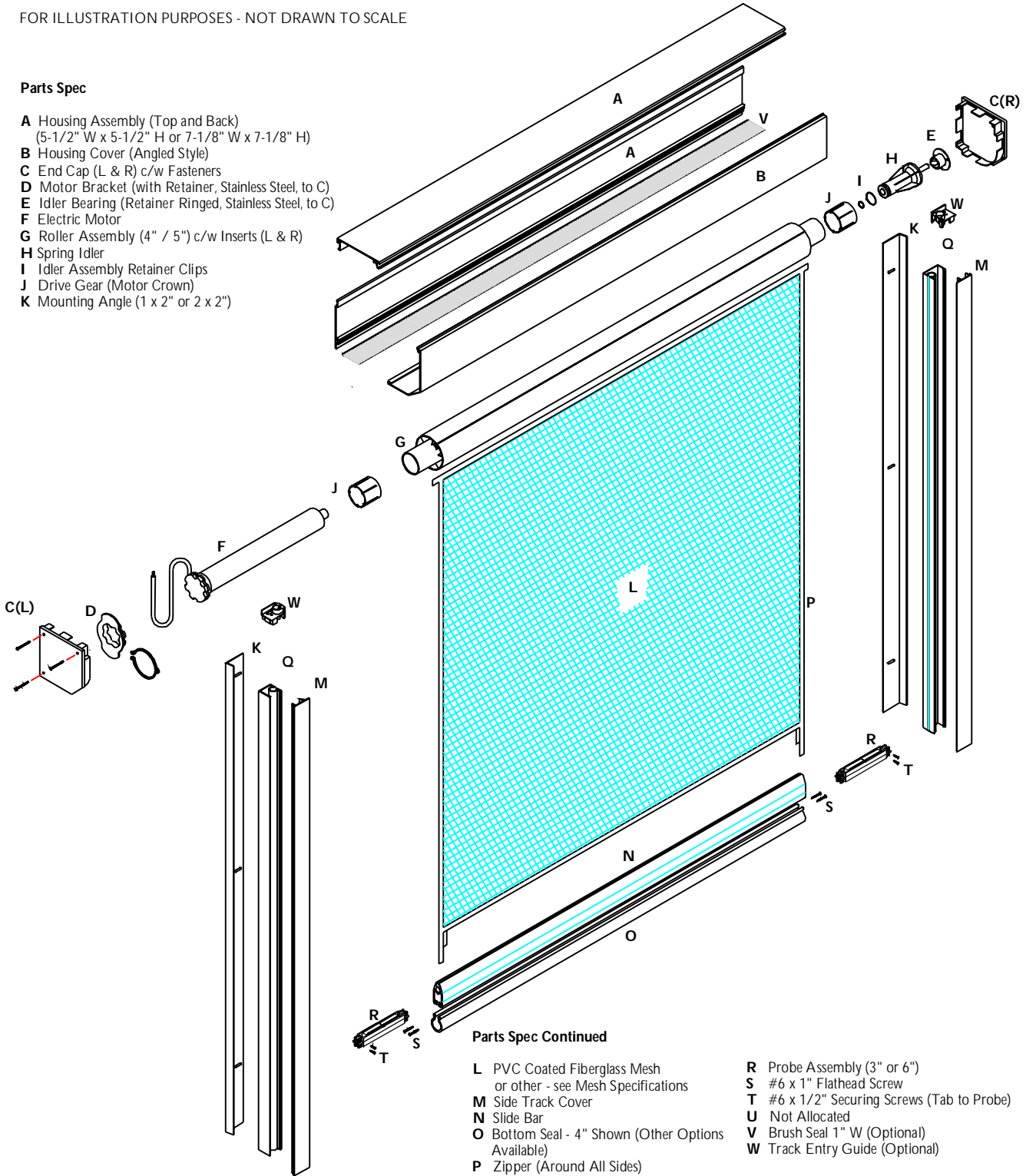

Parts Spec Continued

- L PVC Coated Fiberglass Mesh
or other - see Mesh Specifications
- M Side Track Cover
- N Slide Bar
- O Bottom Seal - 4" Shown (Other Options Available)
- P Zipper (Around All Sides)
- Q Standard Side Track (V2A)
- R Probe Assembly (3" or 6")
- S #6 x 1" Flathead Screw
- T #6 x 1/2" Securing Screws (Tab to Probe)
- U Not Allocated
- V Brush Seal 1" W (Optional)
- W Track Entry Guide (Optional)

Creator: NDR	Date: 06/15/2009	Revision: Rev:
Drawing Title: PSEXECPRODDDESIGNSPEC-SOMFY06(B)		
© 2010 Phantom Mfg. Intl Ltd.		Scale: NTS